

ES	Instrucción de montaje ¡Leer primero!	Barras de aluminio
EN	Assembly instructions Read first!	Aluminium bars
FR	Instruction de montage Lire en premier!	Barres d'aluminium
DE	Montageanleitung Zuerst lesen!	Aluminiumdachträger
PT	Instruções de montagem Ler primeiro!	Barras d'alumínio
IT	Istruzioni di montaggio Leggere per primo!	Barre di alluminio
NL	Montagehandleiding Eerst lezen!	Aluminium dakdragers
PL	Instrukcja montażu Najpierw przeczytaj!	Belki aluminiowe
CZ	Montážní návod Čtěte pozorně!	Hliníková sada tyčí
HU	Szerelési Utasítás Először olvasd el!	Alumínium rudak
HR	Detaljne upute Prvo procitati!	Bare din aluminiu
RO	Instructiuni de montaj Intai cititi!	Aluminijske šipke
RU	Инструкции по монтажу Сначала прочитайте!	Алюминиевые поперечины
GR	Διαβάστε προσεκτικά τις Οδηγίες Συναρμολόγησης!	Μπάρες Αλουμινίου
TR	Öncelikle montaj: Talimatlarını okuyunuz!	Alüminyum barlar
SI	Navodila za sestavljanje Preberite!	Aluminijske prečke

925-79x

Lv7 2023-r3

Modelo-model:

CRUZ Airo Dark R

Lote-Lot-Lot-Lot:



Peso-Weight-Poids-Gewicht:

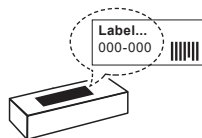

Max. 75 kg / 165 lbs

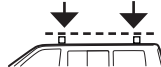

CEE - EEC type approval:



26 R- 04 3016



CITY CRASH (M)

CRUZBER SAU
ES-A14018311
P.I. Las Salinas II
14960 - Rute - Spain
www.cruz-products.com



1.



ES Contenido embalaje: ¡Verificar!

x1

x1

EN Package content: Check!

FR Contenu d'emballage: Vérifier!

DE Packungsinhalt: Überprüfen!

PT Contéudo embalagem:
Verificar!

IT Contenuto della confezione:
Controllare!

NL Pakket inhoud: Controleer!

PL Zawartość opakowania:
sprawdź!

CZ Obsah balení: Zkontrolujte!

HU Csomag tartalma: Ellenőrizd!

HR Sadržaj paketa: Provjeri!

RO Pachetul contine: Verificati!

RU Содержание упаковки:
Проверьте!

GR Ελέγξτε το περιεχόμενο του
πακέτου!

TR Paket içeriğini: Control ediniz!

SI Vsebina paketa: Preverite!



x2



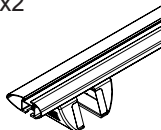

x3



x1

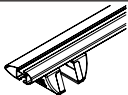

(813-033)

Código Code					Lote Lot
925-791	823-761	108 cm / 43"	2x (749-064) 1x (749-053)	3,81 kg / 8,39 lbs	02/23
925-793	823-763	118 cm / 46"	2x (749-066) 1x (749-053)	4,07 kg / 8,97 lbs	02/23
925-795	823-765	128 cm / 50"	2x (749-067) 1x (749-053)	4,32 kg / 9,52 lbs	02/23
925-796	823-766	133 cm / 52"	2x (749-068) 1x (749-053)	4,57 kg / 10,07 lbs	02/23
925-797	823-767	138 cm / 54"	2x (749-069) 1x (749-053)	4,74 kg / 10,44 lbs	02/23
925-798	823-768	148 cm / 58"	2x (749-070) 1x (749-053)	4,79 kg / 10,56 lbs	02/23

2.



Importante!
Important!
Important!
Wichtig!

- ES ¡Las barras tienen que usarse con sistemas de railing de techo homologados por el fabricante del vehículo!
- EN Bars must be used with roof rails certified by cars manufacturer!
- FR Les barres devront être utilisées avec des railing de toit certifiés pour le fabricant du véhicule!
- DE Die Dachträger müssen mit einer vom Autohersteller geprüften Dachreling verwendet werden!
- PT As barras devem ser utilizadas com rail de tejadillo homologado por o fabricante do veículo!
- IT Le barre devono essere utilizzate unicamente con il sistema railing da tetto omologato dalla casa produttrice dell'auto
- NL De dakdragers moeten worden gebruikt in combinatie met door de autofabrikant goedgekeurde dakrails!
- PL Belki muszą być stosowane z relingami certyfikowanymi przez producenta samochodu!
- CZ Barele transversale, trebuie utilizate cu bare longitudinale, agreeate de producatorul autoturismului!
- HU Tento nosič musí byť používaný pouze na hagusy, ktoré jsou schválené výrobcem vozidla!
- HR A rudak csak a gyár által minősített hosszanti korláttal használható!
- RO Barele transversale, trebuie utilizate cu bare longitudinale, agreeate de producatorul autoturismului!
- RU Поперечины должны быть использованы с рейлингами, сертифицированными производителем транспортного средства!
- GR Οι μπάρες της CRUZ πρέπει να χρησιμοποιούνται σε κάθετες εργασιακές μπάρες πιστοποιημένες από τον κατασκευαστή του αυτοκινήτου
- TR Barlar, araç üreticileri tarafından onaylanmış tavan çitaları ile kullanılmalıdır.
- SI Palice je treba uporabljati s sistemi strešnih nosilcev, ki jih je odobril proizvajalec vozila!

3. 

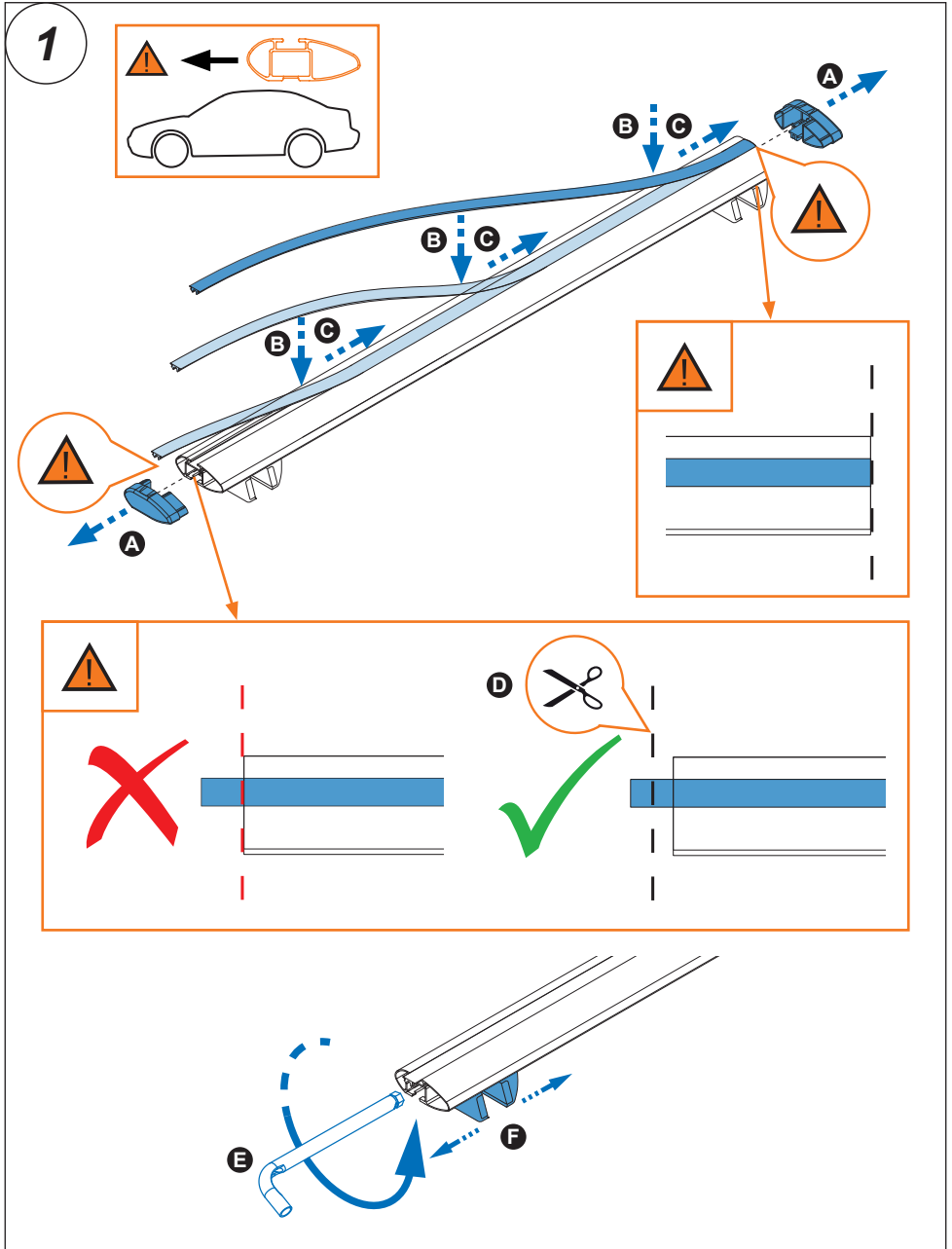

4. 

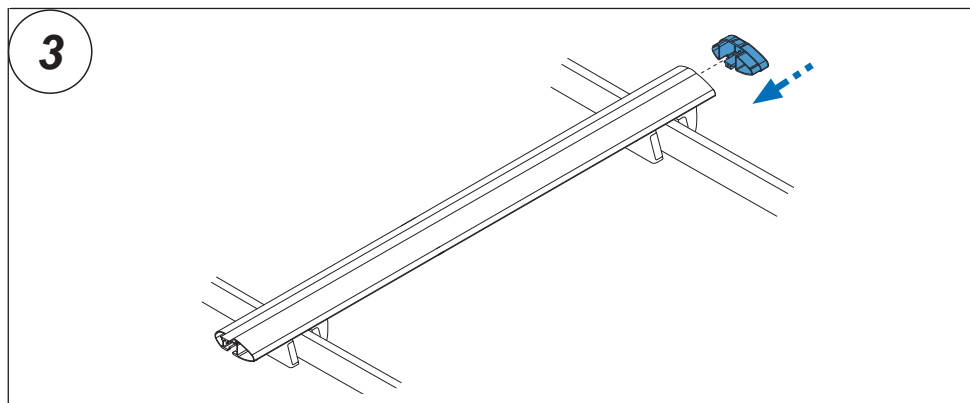
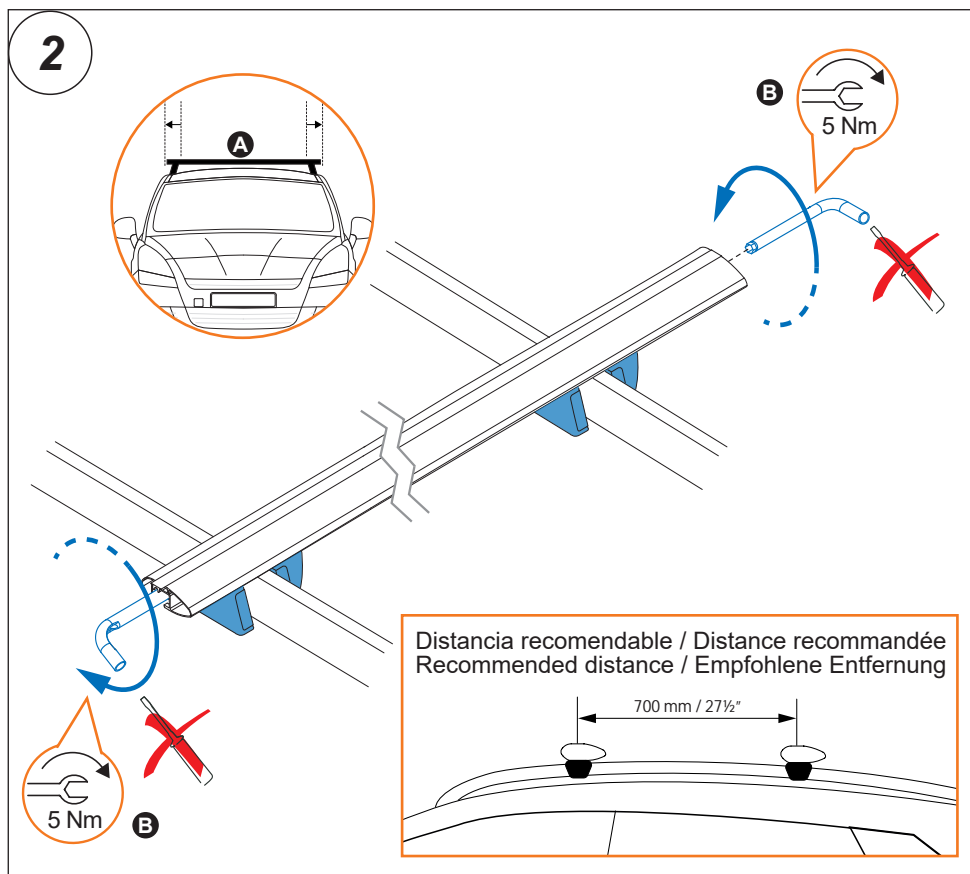

5. 

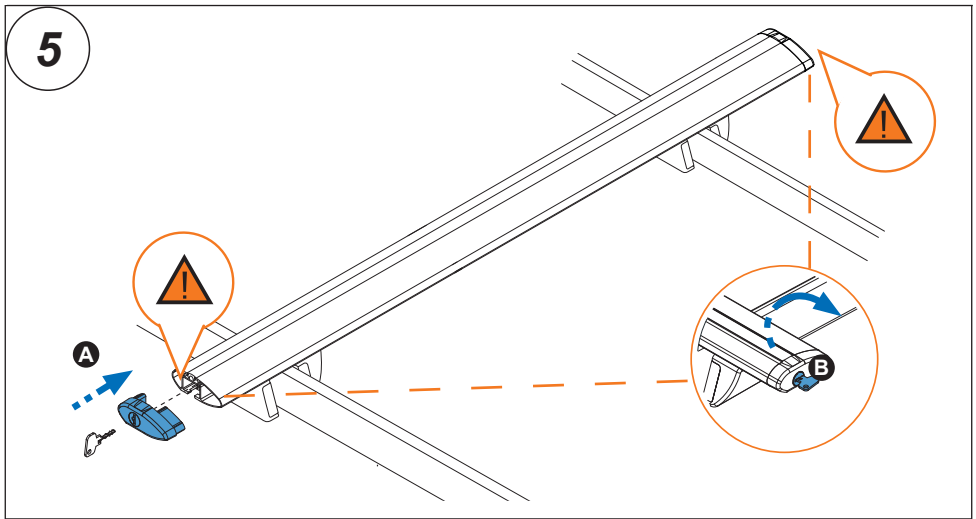
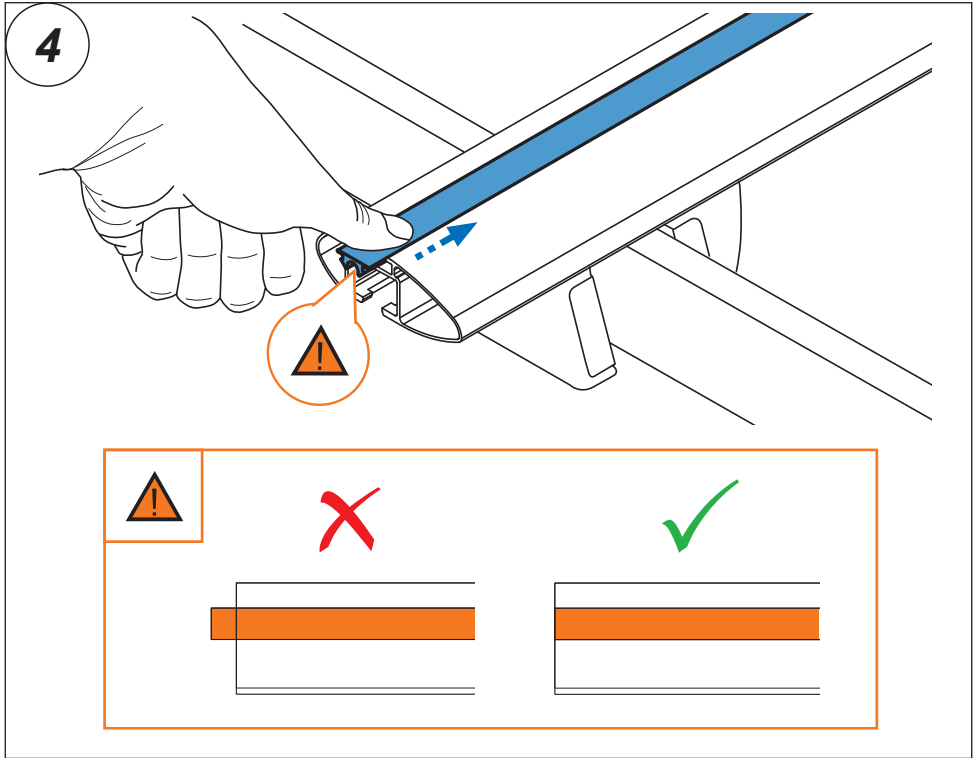

6. 

